

Het G-sportlandschap in Vlaanderen anno 2009 - 2010



Dirk Cossaer
Provinciale Sportraad Antwerpen

Inhoud G-sport Vlaanderen

- Situering internationaal, nationaal, Vlaams, Provinciaal en gemeentelijk niveau
- Definiëring G-sport
- G-sport: breedte – recreatie – competitie – top sport
- De G-sportfederaties binnenstebuiten: Psylos & Recreas & VLG



Internationaal niveau

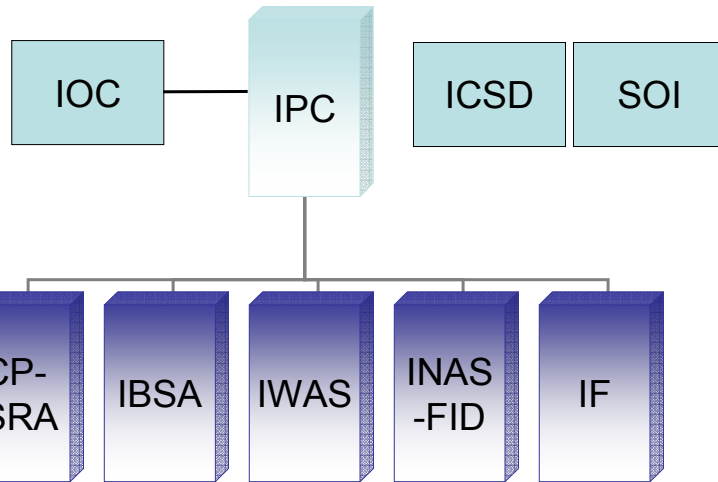

Internationaal niveau

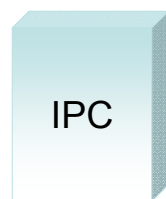

International Paralympic Committee

- Doelgroep: motorische, visuele en verstandelijke
- 20 zomer, 5 winter sporttakken & 1 niet paralympische sport
- Paralympics (jaar van de OS)
- www.paralympic.org



Internationaal niveau



**International
Committee of Sports
for the Deaf**

- Doelgroep: doven en slechthorende
- 20 zomer & 5 winter sporttakken
- Deaflympics (jaar na de OS)
- www.deaflympics.com



Internationaal niveau



**Special
Olympics
International**

- Doelgroep: mentaal gehandicapten
- 34 sporttakken
- Special Olympics (jaar vóór de OS)
- www.specialolympics.org



Internationaal niveau



Cerebral Palsy International Sports and Recreation Association

- Handicapspecifieke sporttakken:
Boccia
Voetbal 7-a-side
- www.cpisra.org



Internationaal niveau



International Blind Sports Association

- Handicapspecifieke sporttakken:
Atletiek, Boogschieten, Bowling,
Gewichtheffen, Goalbal, Judo
Showdown, Sneeuw en
Waterskiën, Tandem fietsen,
Torbal, Voetbal, Zwemmen
- www.ibsa.es



Internationaal niveau



International **W**heelchair
and **A**mputee
Sports **F**ederation

- Handicapspecifieke sporttakken:
Rolstoelscheren
Rolstoelrugby
- www.iwasf.com



Internationaal niveau



International **S**ports
Federation for People with
an **I**ntellectual **D**isability

- 8 sporttakken
Atletiek, Basketbal, Judo,
Ski, Tafeltennis, Tennis,
Voetbal, Wielrennen, Zwemmen
- www.inas-fid.org



Internationaal niveau

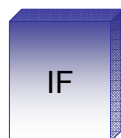

Internationale Federaties

- Autonom of geïntegreerd
- 11 paralympische sporttakken

- Boogschieten (Inter. Archery Federation)
- Paardrijden (Inter. Equestrian Federation)
- Roeien (Inter. Rowing Federation)
- Rolstoelbasketbal (Inter. Wheelchair Basketball Federation)
- Rolstoelcurling (World Curling Federation)
- Rolstoeltennis (Inter. Tennis Federation)
- Schieten (Inter. Shooting Committee for Disabled)
- Tafeltennis (Inter. Table Tennis Federation)
- Volleybal (zit-) (World Organization for Volleyball for Disabled)
- Wielrennen (Inter. Cycling Federation)
- Zeilen (Inter. Foundation for Disabled Sailing)



Nationaal niveau

ICSD
International Committee
of Sports for the Deaf

IPC
International Paralympic
Committee

SOI
Special Olympics
International

BDC
Belgian Deaf Sport
Committee

BPC
Belgian Paralympic
Committee

SOB
Special Olympics
Belgium

VLG vzw
Vlaamse Liga
Gehandicaptensport

LHF asbl
Ligue Handisport
Francophone



Vlaams niveau

- Decreet Vlaamse Sportfederaties
- Decreet Sport Voor Allen
- Participatiedecreet
- Decreet Medische en Ethisch verantwoord sporten

www.bloso.be

www.cjasm.vlaanderen.be/sport/regelgeving



Vlaams niveau

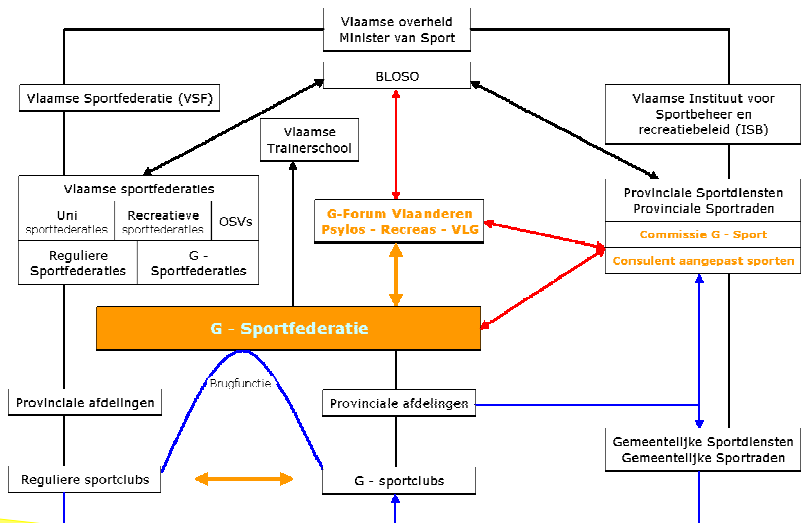

- Advies en overleg
- Samenwerking
- Beïnvloeding

Vlaams niveau

→ 3 door Bloso erkende G-sportfederaties:

- **Psylos vzw**

Vlaamse Federatie voor Sport en Recreatie in de Geestelijke
Gezondheidszorg vzw

- **Recreas vzw**

Recreatief Aangepast Sporten vzw

- **VLG vzw**

Vlaamse Liga Gehandicaptensport vzw



Vlaams niveau

→ Contactgegevens:

- **Psylos vzw**

Valkerijgang 26, 3000 Leuven

Tel: 016 22 04 15 - Fax: 016 23 24 55

E-mail: info@psylos.be - Website: www.psylos.be

- **Recreas vzw**

St-Jansstraat 32-38, 1000 Brussel

Tel: 02 515 02 54 - Fax: 02 511 50 76

E-mail: info@recreas.be Website: www.recreas.be

- **VLG vzw**

Huis van de Sport - Zuiderlaan 13, 9000 Gent

Tel: 09 243 11 70 - Fax: 09 243 11 79

E-mail: info@vlg.be Website: www.vlg.be



Vlaams niveau

→ Andere door Bloso erkende sportfederaties met G-werking, o.a.:

- Nederlandstalige Liga voor Onderwateronderzoek en –Sport
- Sporta – To Walk Again
- Vlaamse Badminton Liga
- Vlaamse Vereniging voor Golf
- Waterski Vlaanderen



Provinciaal niveau Antwerpen



- Coördinator G-sport
- Permanent informatiepunt (PICAS)
- Subsidiereglementen
 - Jeugdsportfonds Camille Paulus
 - Duurzame G-sport werking
 - Internationale evenementen
 - Federaties
- G-sport commissie
- Evenementen
- Regiowerking met G-sport promotoren



Provinciaal niveau Antwerpen



- Sportwijzer
- Provinciaal overleg
- Toegankelijkheidsonderzoek
- Start to G-sport
- Scholenproject "G-sport en jeugd"
- Uitleendienst
- Vorming
- 2 jaarlijks G-sporttak in de kijker: badminton

www.provant.be/vrije_tijd/sport/gehandicapten



Provinciaal niveau Limburg



- Stafmedewerker aangepast sporten
- Secretaris Provinciale G-sportraad
- G-sportraad
- Inventariseren en informeren
- Subsidiereglementen
 - Bijzondere evenementen en projecten
 - Aangepast sportmateriaal
 - Aanpassingen accommodaties
- G-sport organiseren, coördineren, stimuleren en promoten

www.limburg.be



Provinciaal niveau Oost-Vlaanderen



- Beleidsmedewerker G-sport
- Infoloket
- C.A.S.
- Klankbordoverleg werkveld
- Subsidiëring
 - G-sport projecten
 - Toegankelijkheid
- G-sportpromotiedagen
- Uitleendienst



www.oost-vlaanderen.be



Provinciaal niveau Vlaams Brabant



- G-sport commissie
- Sportdagen verstandelijke
- Sportkultur Sportdag ism Psylos
- Handbiken
 - toegankelijk maken van joggingparcours
- G-voetbal, G-paardrijden
- Sportdag voor doven en blinden ism SVS
- Sportkampen
- Subsidiëring
 - G-sport initiatieven



www.vlaamsbrabant.be



Provinciaal niveau West-Vlaanderen



- G-sporttak in de kijker (2 jaar)
- Toegankelijkheidsonderzoek
- Promotie G-sportaanbod
- Subsidiëring
 - evenementen
 - initiatieven
- Interprovinciaal overleg werkveld
- G-sportadvies via prov. Sportraad



Provinciaal niveau West-Vlaanderen



- G-sportevenementen
 - West-Vlaamse 3-daagse A.S.
 - Kriebeldag (visueel)
 - Snoezeldagen
- Informatieverstrekking
 - Reva-beurs
 - A.V. sportraad
- Projecten
 - KAP-project: toegankelijke routes
 - Sociale toegankelijkheid



www.west-vlaanderen.be/sport

Provinciaal niveau Brussel, hoofdstedelijk gewest

VLAAMSE
GEMEENS
CHAPSCO
MMISSIE



- Consulent aangepast sporten
- Infoloket
- Overlegplatform
- Openstellen van reguliere activiteiten
- Subsidiereglement
- Uitleendienst



Provinciaal niveau Brussel, hoofdstedelijk gewest

VLAAMSE
GEMEENS
CHAPSCO
MMISSIE



- G-sport activiteiten
 - Sportdag Aangepast Sporten
 - Aangepaste Bewegingsdag
 - Buitengewoon Sportief Brussel
 - Maandelijkse tandemtochten
 - Infobeurs g-sportclubs voor
 - Dans op maat
 - Sportacademie op maat

www.vgc.be/sport



Gemeentelijk niveau

Gemeentelijke en Stedelijke Sportdiensten:
zeer verscheiden aanpak:

- Consulent aangepast sporten
- Subsidiereglementen
 - Algemene
 - Specifieke
- G-sportdag(en) of andere initiatieven

Bij voorkeur grensoverschrijdende en duurzame aanpak !



Definiëring G-sport

Het zijn die personen die omwille van een functiestoornis niet volwaardig aan het reguliere sportaanbod kunnen participeren.

Een functiestoornis is een afwijkende functie van de fysiologische en/of mentale eigenschappen van het menselijk organisme, ofwel een afwijkende anatomische structuur wat betreft positie, vorm en continuïteit van onderdelen van het menselijk lichaam.



Definiëring G-sport

- **G-sport:** Elke sportparticipatie uitgeoefend door personen met een handicap
- **G-sporttak:** Sporttak die specifiek voor personen met een handicap ingericht wordt, bv. boccia, goalbal, ...



Definiëring G-sport



exclusief

« **organisatorische integratie** »

inclusief

G-sportclub exclusief voor personen met een beperking, aangesloten bij een G-sport federatie, neemt deel aan G-sport (recreatieve) competitie	...	G-sportploeg als ploeg ondergebracht onder een reguliere club, neemt deel aan G-sport (recreatieve) competities. Deze G-ploeg maakt deel uit van normale clubleven.	G-sportploeg als ploeg ondergebracht onder een reguliere club die deelneemt aan de reguliere (recreatieve) competitie.	...	Een sporter met een beperking aangesloten bij een reguliere club, als sporter onder valide sporters.
-----------------------------------------------------------------------------------------------------------------------------------------------	-----	---------------------------------------------------------------------------------------------------------------------------------------------------------------------	------------------------------------------------------------------------------------------------------------------------	-----	------------------------------------------------------------------------------------------------------



Definiëring G-sport

- **Inclusief:** Personen met en zonder handicap sporten met en tegen elkaar. Een andere term is 'volledig geïntegreerd sporten'. Dit komt vaak voor wanneer de spelregels en het speelveld niet of nauwelijks moeten aangepast worden, dus zelfde locatie, tijdstip en reeks.
- **Exclusief:** Personen met een handicap doen aan sport binnen een sportclub of organisatie uitsluitend bestemd voor personen met een handicap. Dit wordt ook vaak het 'categoriaal aanbod' genoemd, d.w.z. andere locatie, andere tijd en andere reeks.
- **G-afdeling:** Personen met een handicap sporten binnen een reguliere sportclub in een aparte afdeling voor personen met een handicap. Hiernaar wordt dikwijls ook verwezen als 'organisatorisch geïntegreerd sporten', m.a.w. zelfde locatie, zelfde of andere tijd en andere reeks.



G-sportfederaties



1. Missie

Psylos vzw

verhoogt de sportparticipatie van personen met een psychische beperking en gaat en staat voor een kwalitatief sportaanbod met als doel voor elk van deze sporters een **zo hoog mogelijke graad van integratie** in het sportlandschap te bekomen.



www.psylos.be

G-sportfederaties

2. Doelstellingen



Psylos vzw

- organiseren van (competitiegerichte) recreatieve sportbeoefening
- organiseren van kaderopleiding en bijscholing
- begeleiding van aangesloten G-sportclubs
- sportpromotie
- overlegplatform met informatieopdracht (expertise)
- medisch en ethisch verantwoord sporten/gezonde levensstijl
- brugfunctie met reguliere sportclubs



www.psylos.be

G-sportfederaties

3. Organogram

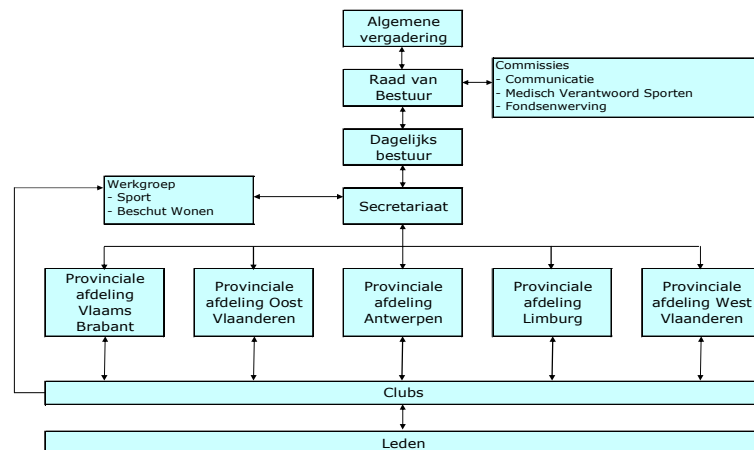

www.psylos.be

G-sportfederaties



4. Aantal clubs

Psylos vzw: 40

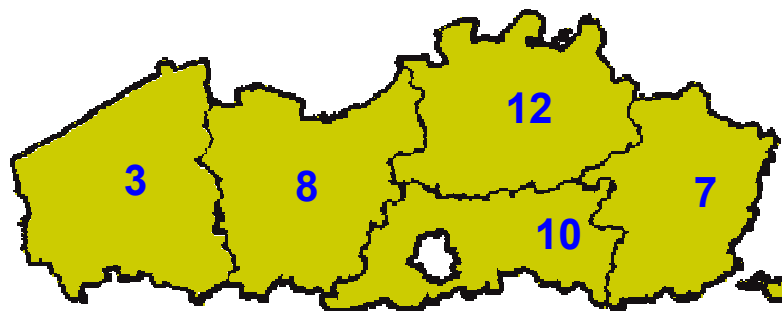

www.psylos.be

G-sportfederaties



5. Aangesloten leden

Provincie	Aantal leden
Antwerpen	887
Limburg	693
Oost-Vlaanderen	638
Vlaams-Brabant	827
West-Vlaanderen	453
VGC	0
TOTAAL	3498



www.psylos.be

G-sportfederaties



6. Sportaanbod in eigen clubs

- Exclusief in functie van de vraag van de eigen clubs
- Inclusief in functie van de samenwerking met de reguliere sportfederaties

- Vlaamse Wandel Federatie



www.psylos.be

G-sportfederaties



1. Missie

- **Recreas vzw is:**
 - Een door BLOSO erkende en gesubsidieerde recreatieve sportfederatie gelinkt aan de Socialistische Mutualiteiten.
- **Recreas vzw richt zich naar:**
 - Personen met een handicap, chronisch zieken, invaliden, familie en vrienden, ongeacht hun ideologische overtuiging.
- **Recreas vzw wil:**
 - Dat zoveel mogelijk personen met een handicap in Vlaanderen op regelmatige en kwaliteitsvolle wijze aan recreatieve sportbeoefening kunnen doen.
Recreas tracht hierover tevens te sensibiliseren.



www.recreas.be

G-sportfederaties

2. Doelstellingen



Recreas vzw:

- Op kwaliteitsvolle wijze recreatiesport aan te bieden.
- Met het aanbieden van recreatiesport willen we zoveel mogelijk mensen met een handicap laten sporten. Ons aanbod is dan ook breed en laagdrempelig (sport voor allen).
- Dermate veel aangepast sportaanbod voorzien zodat de persoon met een handicap zelf zijn plaats kan kiezen op het continuüm: inclusief-exclusief.



www.recreas.be

G-sportfederaties

3. Organogram

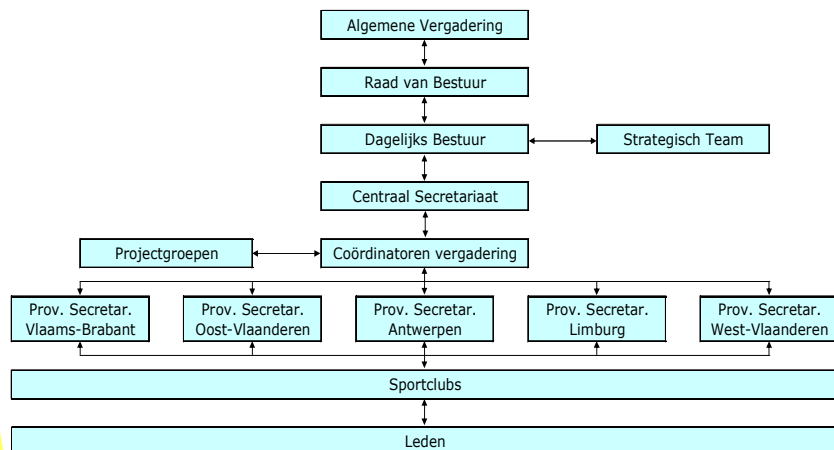

www.recreas.be

G-sportfederaties

4. Aantal clubs

Recreas vzw: 99 clubs

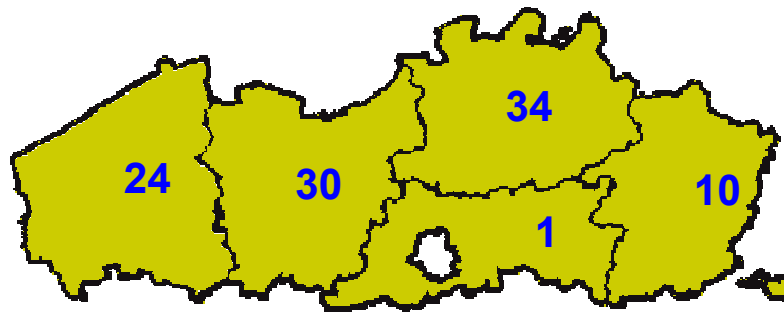

www.recreas.be

G-sportfederaties

5. Aangesloten leden

Recreas vzw: 3.921 leden



Antwerpen	927
Limburg	303
Oost-Vlaanderen	1.193
Vlaams Brabant	8
West-Vlaanderen	1.490
TOTAAL	3.921



www.recreas.be

G-sportfederaties

6. Sportaanbod in eigen clubs



- Exclusief in functie van de vraag van de eigen clubs
- Inclusief in functie van de samenwerking met de reguliere sportfederaties

- FROS Amateursportfederatie
- Gezinsportfederatie
- Natuurvrienden Sportfederatie
- Sporcrea
- Senioren Sportfederatie



www.recreas.be

G-sportfederaties

1. Missie



VLG vzw is

Een landelijke sportfederatie die zich richt naar personen met een handicap en die streeft naar **normalisatie** op het vlak van en door middel van aangepaste bewegingsactiviteiten en aangepast sporten.



www.vlg.be

G-sportfederaties

2. Doelstellingen



VLG vzw

- Recreatief en competitief sportaanbod
- Integratiebeleid
- Clubondersteuning
- Kenniscentrum: opleiding en classificatie
- Management: administratie, communicatie, ...
- Promotie
- Topsport
- Events



www.vlg.be

G-sportfederaties

3. Organogram

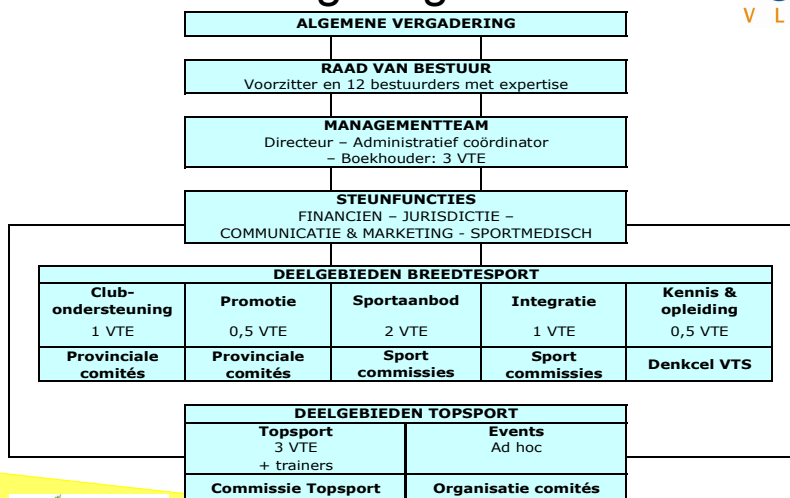

www.vlg.be

G-sportfederaties

4. Aantal clubs

VLG vzw: 55 clubs

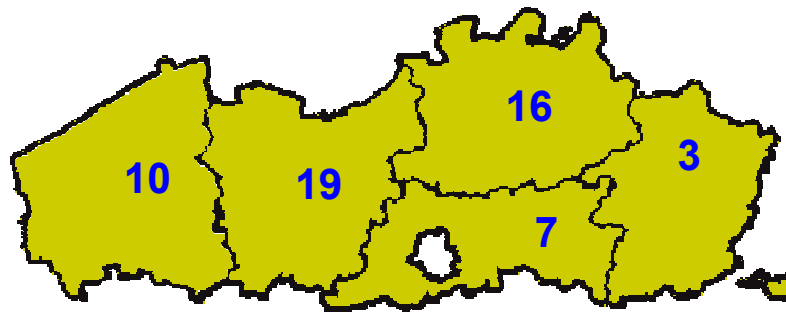

www.vlg.be

G-sportfederaties

5. Aangesloten leden

VLG vzw: 2.296 leden

- 45 % motorisch
- 45 % verstandelijk
- 10 % visueel

- 20 % jonger dan 18 jaar

- 50 % competitief
- 50 % recreatief



www.vlg.be

G-sportfederaties

6. Sportaanbod in eigen clubs



- Exclusief in functie van de vraag van de eigen clubs
- Inclusief in functie van de samenwerking met de reguliere sportfederaties
 - Vlaamse Atletiek Liga vzw
 - Vlaamse Basketbal Liga vzw
 - Wielerbond Vlaanderen vzw
 - Vlaamse Liga Paardensport vzw
 - Gymnastiek Federatie Vlaanderen vzw
 - Vlaamse Judo Federatie vzw
 - Vlaamse Ski- en Snowboard Federatie vzw
 - Vlaamse Zwemfederatie vzw
 - Vlaamse Tennis Vereniging vzw



www.vlg.be

G-sportfederaties

7. Topsport – VLG vzw



DOEL:

Het creëren van een prestatiebevorderende omgeving voor de talentvolle, de beloftevolle en de elitesporters met een handicap.

- Commissie topsport
- Prestatie + totaalrapport van prestatiebepalende factoren
- Ondersteuning van 12 topsporters individueel + 4 teamsporten
- Talentwerking basketbal, boccia, tennis, zwemmen



www.paralympic.be
www.vlg.be

G-sportfederaties

7. Topsport – VLG vzw



→ Evolutie van de deelnemende landen aan de Paralympics

→ Evolutie van het aantal Belgische medailles

Paralympic Games	Aantal atleten	Aantal landen	Aantal medailles	Goud	Zilver	Bronz
1960 Rome	400	23	291	1	1	1
1992 Barcelona	3001	83	1503	5	5	7
1996 Atlanta	3259	104	1577	8	10	7
2000 Sydney	3881	123	1657	1	4	4
2004 Athene	3806	135	1567	3	2	2
2008 Beijing	3951	146	1431	0	0	1
2012 London	4000	150				

www.paralympic.be

www.vlg.be



Bedankt voor uw aandacht !